



news

www.PanteraClubNorCal.com

Volume 29

Issue 9

September 2002

PRESIDENT

Steve Liebenow
(408) 727-8678
Steven.Liebenow@att.net

VICE PRESIDENT

Dave Crego
(408) 377-9980
DCrego@earthlink.net

SECRETARY

Mike Drew
(707) 452-9284
MikeLDrew@aol.com

TREASURER

Jim Kuehne
(408) 244-7095
JKuehne@kuehneconstruction.com

CLUB STORE

John Hansen
307-732-1818
PCNCStore@yahoo.com

LIBRARIAN

Sharon Renshaw
(925) 372-7021
KittyLuvr480@aol.com

RAFFLE CHAIRMAN

Larry Stock
(650) 964-1531
SharLar@Sierra.net

NAME BADGES

Doris Britschgi
(408) 866-1677

WEBMASTER

Mark McWhinney
(650) 906-6275
msm@powertest.com

**MEMBERSHIP
COORDINATOR**

Russ Britschgi
(408) 866-1677

**EVENTS
COORDINATOR**

Diane Dean
(408) 683-4861
DeanD@inreach.com

**MOTORSPORTS
COORDINATOR**

Charlie Puckett
(707) 762-7307
pantini74@attbi.com

Minutes of Meeting 29 August, 2002

The meeting was called to order at 8:12 by president Steve Liebenow. All officers were present except for John Hansen, Dave Crego and Mark McWhinney. Charlie and Karen Puckett made a special appearance, driving all the way down from Petaluma. There were 37 people signed in, and 15 De Tomaso cars in the parking lot.

For a club that boasts a principally co-ed membership, there were an unusually high number of XY chromosomes in the room. Noting the highly skewed ratio of men to women in the crowd, one member quietly remarked that unlike most meetings, this meeting was "a sausagefest."

New Members/Guests: The club welcomed **Jim Murch** to the fold. Jim is actually an NOS member; he was an active participant in PCNC back when the club used to meet at the Round Table



A fine turnout of De Tomaso automobiles graced the parking lot

expenses were paid, the final accounting has yet to be finished, so we don't know if we made or lost money on the event. Furthermore, Anita went on a trip to Oklahoma and Jim can't find the club checkbook! So there will be no treasury activity until she gets back.

Club Store Report: As the club store manager is in Wyoming, there was no activity to report. Carl and Mary Schumaker have volunteered to be the Club Store Elves, delivering orders at the meeting each month.

Club Library Report: The Renshaws had the contents of the club library in the back of their car. Although the library is slowly growing, they are always looking for contributions. New members are especially invited to take a look at the library's contents, and borrow whatever books/magazines/articles/videos raise interest.

Past Events:

Monterey Historic Races/Concorso Italiano: The Concorso Italiano continues to grow, and the De Tomaso contingent put on a great show, with some 45 De Tomaso cars on the lawn, including one Mangusta, and the very first De Tomaso automobile, the Formula 2 car with serial number 0001.

De Tomaso owners booked the entire Los Laureles Lodge, but at the last minute one couple had to cancel due to a family emergency. Tony fortunately was able to sell the room to a drop-in, a non-car person looking for a place to stay, in town for a wedding or something.

The dinner was exceptional, and well-attended with over 120 people sharing in the festivities. There were 17 Panteras and a Mangusta lined up all around the tables; not a chance of getting one more car in!

The dinner featured a Hawaiian Luau theme, complete with lots of decorations and smoking Tiki torches at each table. Tony's girlfriend Linda is to be especially commended for a fine job, not only with coordinating the decorations, but also for slyly booking genuine Hawaiian entertainers without Tony's knowledge, who came with a pair of beautiful hula dancers to celebrate Tony's 50th birthday!

Dave and Linda Adler of Pantera International out-did themselves at the racetrack, putting on

restaurant in San Mateo (sometime during the 1970's.) He owns a white '73, #5539, that he purchased brand new directly from the Ford Motor Company in 1974.

Changes To Last

Month's Minutes: Although Doris has retired from teaching, she is still grading papers—circling typos in the newsletter. None were significant enough to mention, however.

Club Treasury Report:

After all the Monterey ex-

a barbecue which was by orders of magnitude greater than any in years past. The food was simply splendid, and numerous people commented on the wonderful ambiance and the excellent food—well worth the price.

The races were excellent, as usual, and the weather was terrific as well. Everyone who attended agreed that the Monterey weekend is a must-do event!



Over 120 people enjoyed the sumptuous Hawaiian Luau

Upcoming Events:

Silver State Road Race — 21-22 September: Although this event is theoretically full (with nine Panteras signed up so far), the organizers reportedly love the Pantera participation and will accept late Pantera entries. Anyone interested in participating is invited to contact Larry Stock for information.

Club Dyno Day At Mustang Ranch?: Greg Jacobs is interested in organizing a Dyno Day to be held at the Mustang Ranch in Santa Clara. He will report back to us with further details.

Nor-Cal Donut Derelicts: Donut Derelicts is a huge social affair in Huntington Beach, down in Southern California. Literally hundreds of hot rods appear in the parking lot of an otherwise unremarkable donut shop each Saturday morning starting at about 5:30 a.m., and all are gone by 8:00 a.m. A companion event has been going strong in Atlanta for the past year or so, and now Greg Jacobs wants to start a Bay Area version. Watch for information in an upcoming newsletter.

News, Clues & Rumors:

Qvale Mangusta, Anyone?: One member overheard a conversation in Monterey in which it was mentioned that there are 37 brand new Qvale Mangustas sitting in a warehouse in New Jersey. This perhaps represents a great buying opportunity for anybody interested in one....

De Tomaso Chassis Blueprints: Mike Drew showed off a set of four poster-sized De Tomaso chassis diagrams, a gift to him from the Swedish De Tomaso Club. These would make for some fine garage artwork. It's possible that they may become an addition to the PCNC or POCA club stores. PCNC will be contacting the factory to arrange for duplication/distribution rights.

Anonymous Gifts: Somebody noticed a pair of packages left in the back of the meeting room. These gifts were a case of Foster's Beer, for Jim Kuehne, and a beautifully framed 427 Cobra photograph, for Mike Drew. These were delivered by a club member to express appreciation for the hand-delivery of a Rick Moseley relay kit from Sacramento. Rick has a policy of

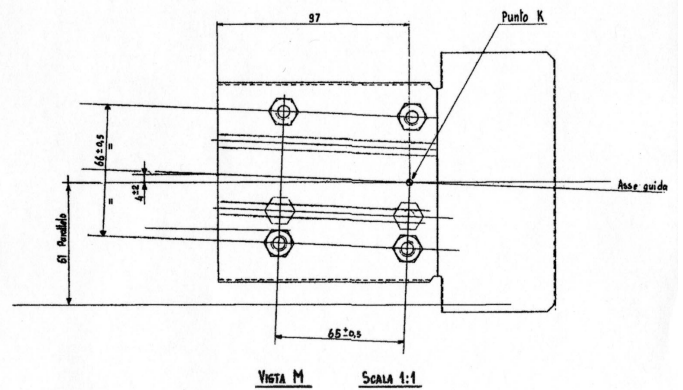
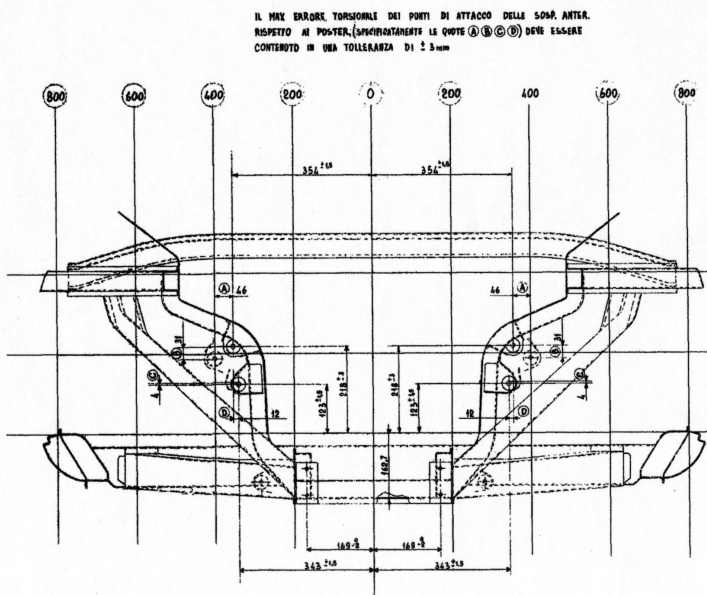
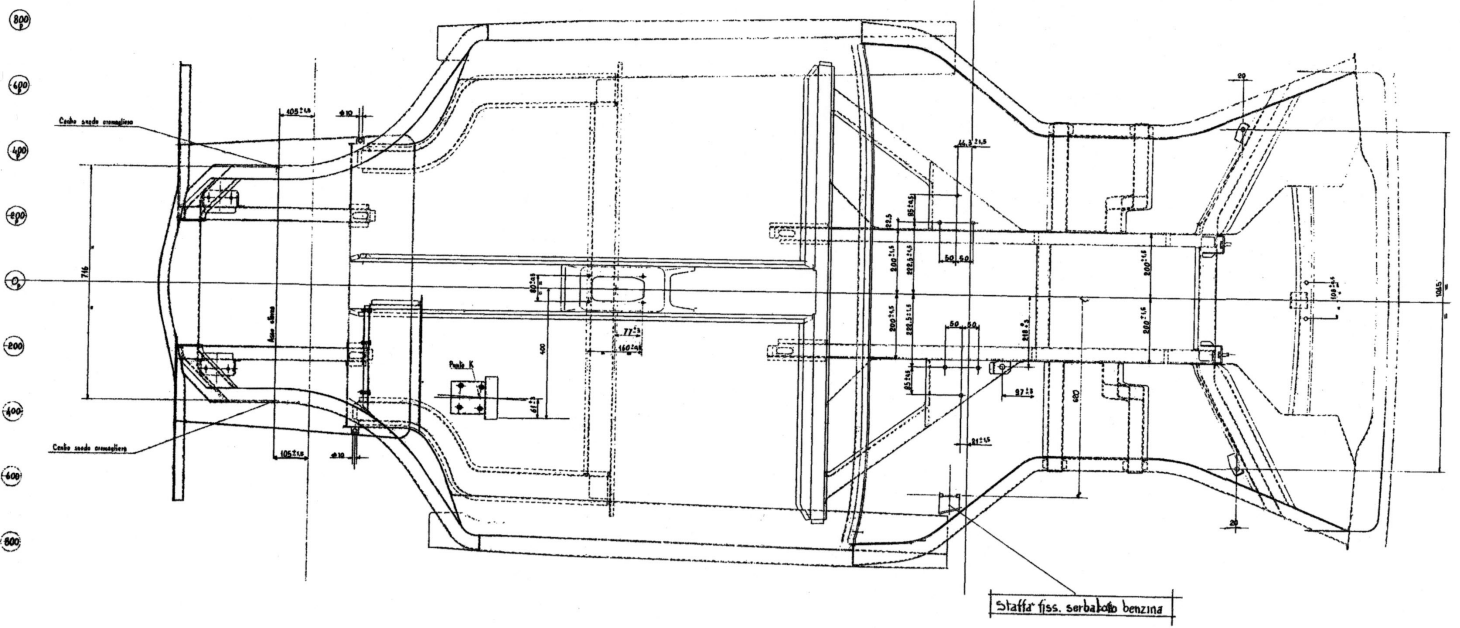



The original drawing was provided by DeTomaso Modena S.p.A.
This copy is restored and reprinted by the Swedish DeTomaso Club.
All rights belong to DeTomaso Modena S.p.A.

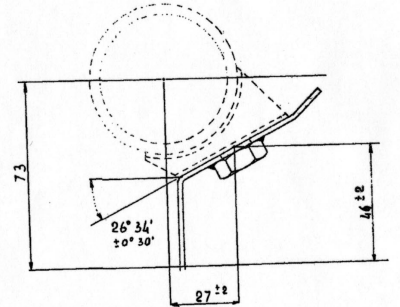
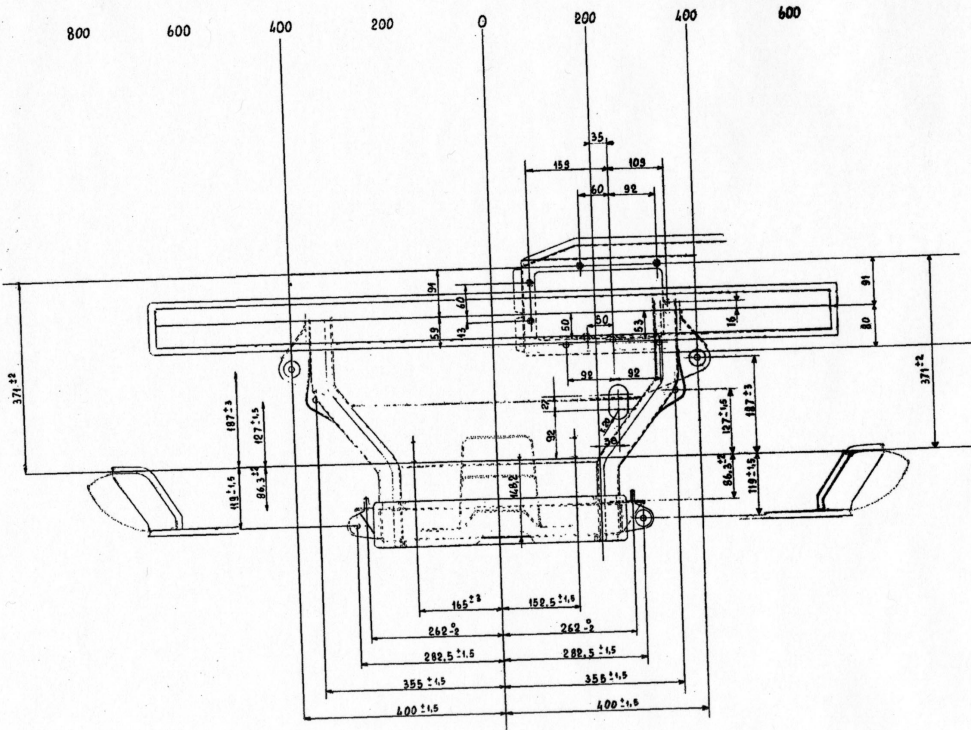

PARTIC. N SCALA 1:1



The original drawing was provided by DeTomaso Modena S.p.A.
This copy is restored and reprinted by the Swedish DeTomaso Club.
All rights belong to DeTomaso Modena S.p.A.

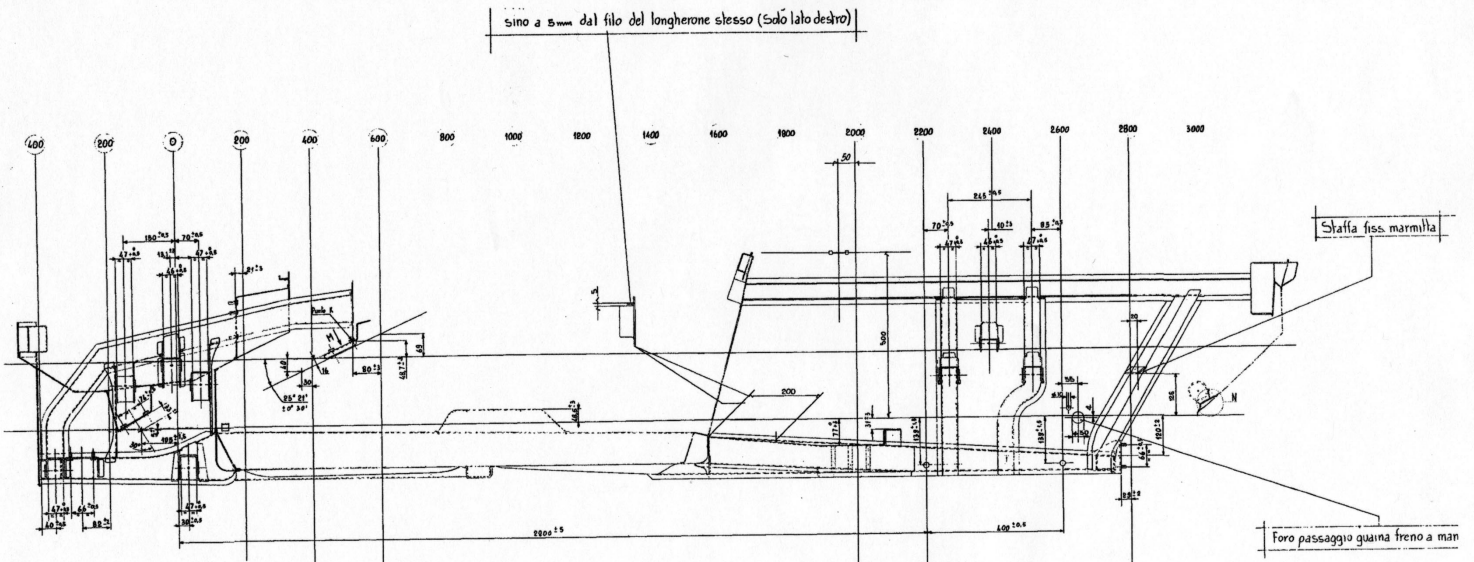

charging shipping fees if he sends a kit via UPS, but if the kit is hand-delivered, he asks that the shipping fees be converted into beer for Jim, since he provides the mounting brackets!

Operation BOHICA: Anyone with military experience will recognize the acronym, which stands for Bend Over, Here It Comes Again. PCNC member and POCA Store co-chairman Asa Jay Laughton was nearing the end of his one-year Air National Guard tour in Saudi Arabia, and actually had an airplane ticket in hand for his flight home and subsequent retirement, when the military made the decision to extend 15,000 guardsmen and reservists by an additional year, including Asa Jay. His ticket to freedom thus went up in smoke and he's stuck in the desert for the foreseeable future.

E-mail is always appreciated by folks in his position; Asa Jay's address is:
asa.laughton@dhafra.af.mil

Driving For Dinner Raffle: The lucky winners were Carl and Mary Schumaker, who drove their Pantera which itself is a raffle prize for a benefit raffle.

Raffle Results: Thanks to Carl & Mary donating a pair of gold rings, almost \$200 worth of tickets were sold, a new club record! In a stunning display, inspired by the presence of the rings, Ken Levin opened up his wallet, and withdrew *five* U.S. dollars (along with a dead moth) and purchased more tickets than at any time in his 30 years in PCNC.

The results were:

Dunlop vintage racing posters — Mark Tumbarello, Carl Schumaker
Best Productions T-shirt — Darryl Warriner
Misc. Catalogs — Jason Easton, Carl Schumaker
Pantera Parts Connection hat — Steve Liebenow
Pantera video — Rich Boschert
Rings — Ron Hanner, and Ken Levin! (He was sweating!)
ZF Drain Plug Tool — Ken Levin

The meeting adjourned at 9:50 p.m., with the last members leaving the parking lot BS session sometime after midnight!

A Correction

In Steve Bogart's article entitled "Electrifying Bedtime Stories" in a previous issue of this newsletter, he incorrectly stated the values of the resistor needed to create the amperage tester rig. The correct values for the resistor should be 10 watts, 0.1 ohms, 1% tolerance. Steve is utterly embarrassed by this screw-up, and appologizes for the mistake. If anyone has further questions, please e-mail Steve at sbogart@denalisoft.com

New Hot Wheels Model Hits The Shelves

A brand-new 1/18th scale Pantera model has suddenly hit the shelves of toy stores and chain stores everywhere. The model, available only in red, is from Mattel/Hot Wheels, and is a build-it-yourself version of the popular already-assembled replicas which have been available for a year or so (but which have been discontinued, and thus are more and more difficult to find).

The model is an almost perfect reproduction of Gary Hall's "Big Red", an early Pantera converted to GT/4 specifications. Ironically, the suggested retail price is much higher than the previous issue—you have to pay more to build it yourself!

These models are being marketed to retailers in a rather bizarre fashion, making them virtually impossible to special-order. Retailers simply order a case of models, and inside the box is a



The new model comes painted, but not assembled



The back cover shows a yellow Pantera reduced to its component parts. Assembly should be fairly straightforward

random collection of cars, which may or may not include the Pantera. It will take some diligence to find one on the shelf, and since they are being marketed in a very limited run, once they are gone, there will likely be no more.

If you ever had the yearning to customize the Mattel/Hot Wheels Pantera, this represents a golden opportunity! Buy one or live to regret it...

Day of the Dead Tech Session

Saturday, November 2nd at
Roger & Pam Sharp's

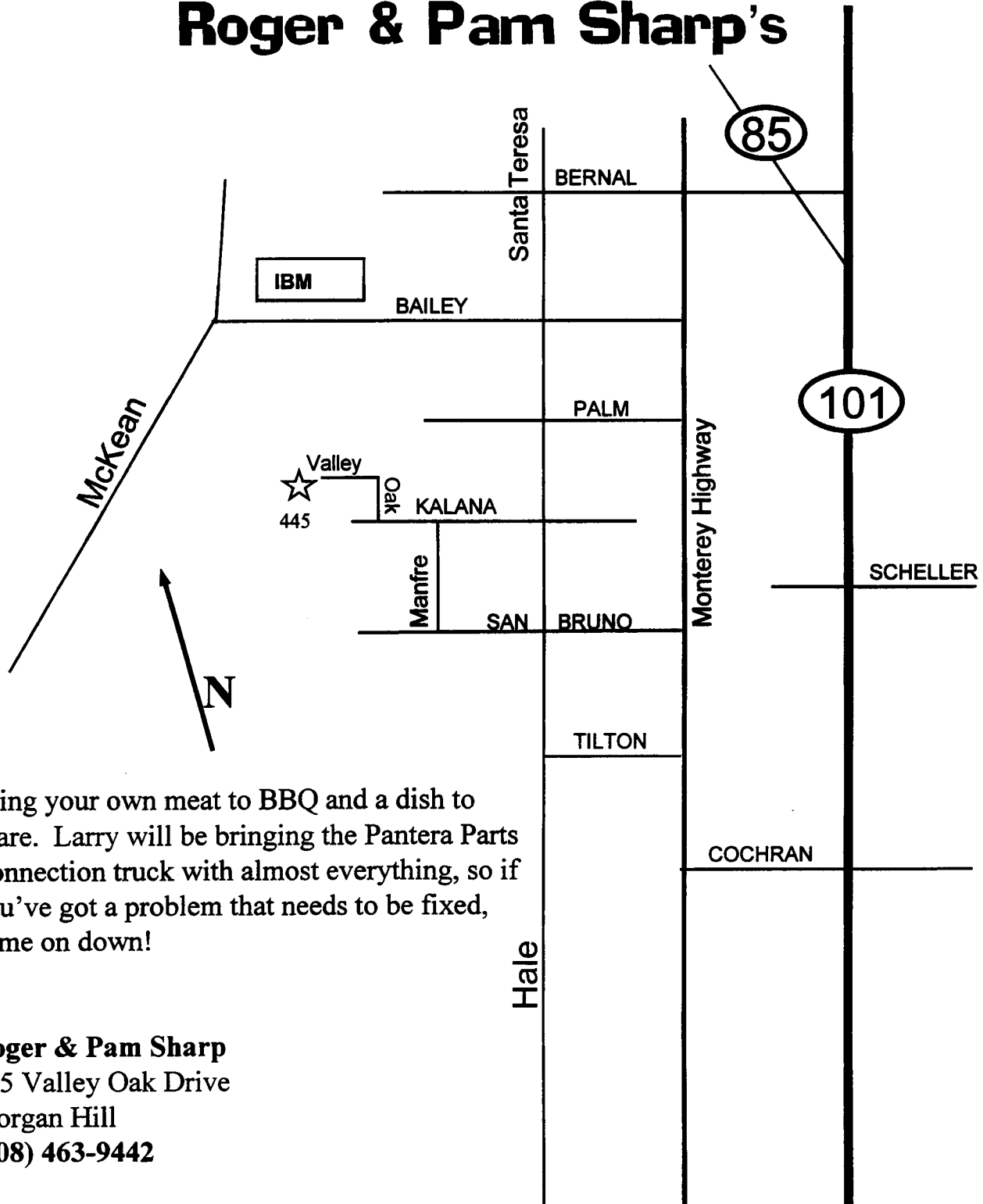

Bring your own meat to BBQ and a dish to share. Larry will be bringing the Pantera Parts Connection truck with almost everything, so if you've got a problem that needs to be fixed, come on down!

Roger & Pam Sharp
445 Valley Oak Drive
Morgan Hill
(408) 463-9442

NEXT CLUB MEETING

**THURSDAY, September 26, 2002
8:00 P.M.**

**COCO'S RESTAURANT
1209 OAKMEAD PARKWAY
SUNNYVALE, CA
(Take Lawrence Expressway South Exit off Highway 101)**

UPCOMING CLUB EVENTS

September 21-22 ————— Silver State Road Race (Larry Stock)

TBA ————— Dyno Day (Greg Jacobs)

TBA ————— Nor-Cal Donut Derelicts (Greg Jacobs)

November 2 ————— Day of the Dead Tech Session (Roger Sharp)

REMINDER — NEWSLETTER ARTICLES DUE BY 15th OF EACH MONTH
www.PanteraClubNorCal.com



Mike Drew
136 Lighthouse Way
Vacaville, CA 95688

PCNC Hosts the Monterey Historics Weekend

Story and Photos by Mike Drew

Once again, the members of PCNC descended upon the Monterey Peninsula to join in the orgiastic celebration of all things automotive which has become known simply as “the weekend”. Spearheading our assault was Tony Harvey, who spends countless hours ensuring that everything happens Just So.

People started arriving on Thursday afternoon at the Los Laureles Lodge, some driving from southern California and others flying in from various points across the country. There to greet them was Todd Glycer, PCNC’s Hospitality Chairman, who ensured the hospitality suite was fully stocked with suitable libation and munchies.

Friday morning dawned all too early, and people hopped into their cars for the short drive down the hill to the Quail Lodge, where the Concorso Italiano continued its recent growth trend. The eventual lineup of cars stretched much further than in years past. The De Tomaso contingent was moved to a different spot on the grass, and De Tomaso participation was up to a total of 45 cars, including one Man-



Randy Timm speaks with Keith Martin about his extremely original 1974 Pantera, the last Pantera imported and sold by Lincoln-Mercury.

gusta, and the Adlers De Tomaso number 0001.

Tom Matano, the chief of Mazda design, who used his own Vallenga as the prime inspiration for the Mazda Miata and 626, gave design commentary as the various De Tomaso cars were driven across the stage. Later, Dave Adler handed out the Pantera International people’s choice awards.

Back at the Lodge, Tony was hustling to ensure the final preparations were completed for the big luau. Eventually

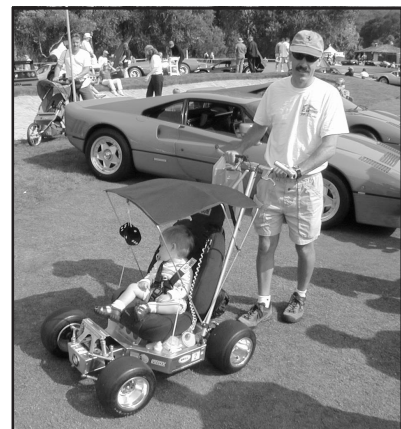

Enthusiasm begins early in Monterey! Check this stroller, with fully independent suspension, slicks, four-wheel disc brakes, Simpson racing seat and five-point harnesses!



Randy accepts an award from Dave Adler



Concorso Italiano was the first time most of us got to see the new Lamborghini; there were several of them scattered around



One of the more interesting exhibits was this unrestored Ferrari transporter with two Ferrari "barn cars" on the back

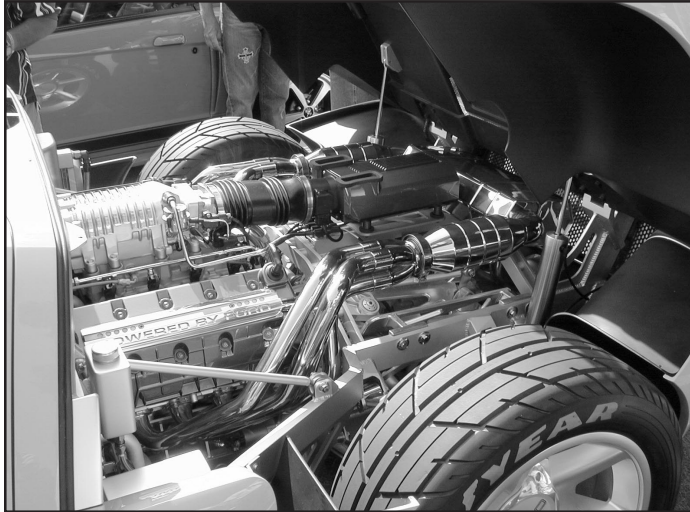

The new GT40 engine is a true work of art. The quality of the fabrication is worthy of anything NASA has ever launched!

over 120 people enjoyed a fine outdoor BBQ, amidst a De Tomaso car display orchestrated by Jack DeRyke. The inclusion of Hawaiian musicians and hula dancers was a surprise event to Tony himself, arranged at the last minute by his wily girlfriend, who used the opportunity to give Tony a surprise 50th birthday present!

Following the dinner, most people trooped up to the hospitality suite, where Todd Glycer's new Pantera video received its unveiling. It met with universal approval, and sales were brisk. Copies are available from Pantera Parts Connection and Hall Pantera, among others.

The next day, the Pantera International folks were putting on a show of their own, with a big tent and a massive trackside BBQ. Those who paid for the coral pass and BBQ got Laguna Seca's first-rate parking (flat dirt, as opposed to hilly dirt!), drinks and refreshments all day long, and a terrific lunch. The food was absolutely exquisite, and of course the company was top-notch!



Ford took the opportunity to show off the new GT40, which was swarmed with people all weekend long

Various POCA members could be found among the race participants, including PCNC's Rick O'Brien running his '66 Shelby GT-350, and Gold Country Panteras' Carl Stein in his '66 Shelby Trans Am Mustang.

Saturday evening saw a large number of us enjoying a

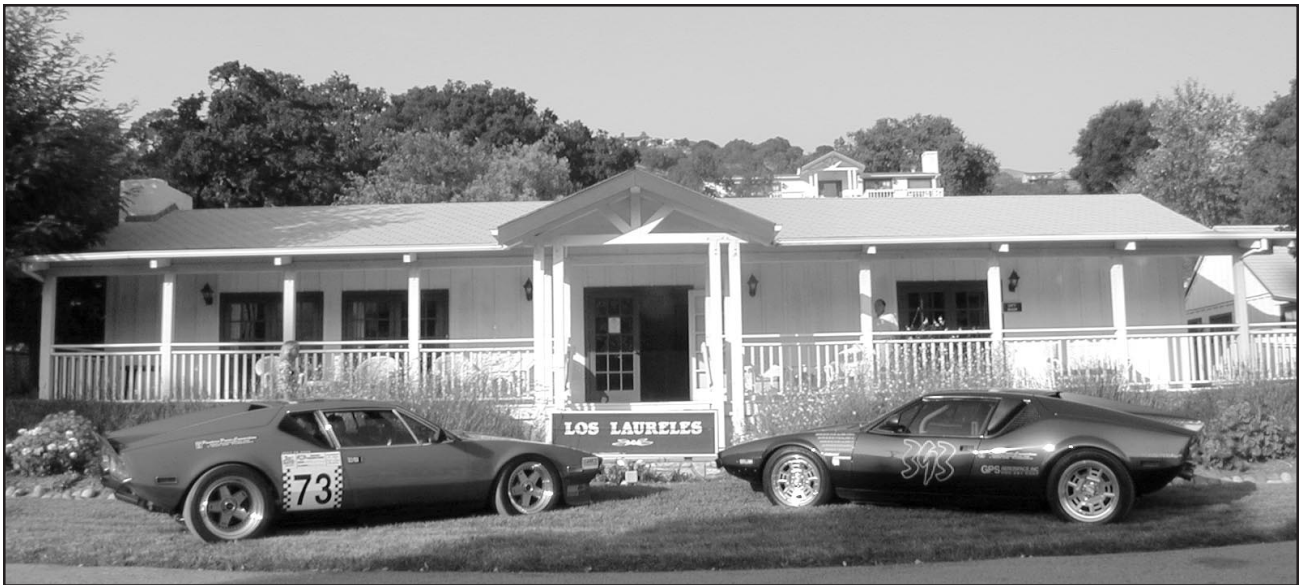

The Silver State race Panteras of Larry Stock and Dennis Antenucci parked in front of the hotel office

dinner in the hotel restaurant, while others took the opportunity to explore the varied cuisine the Monterey peninsula has to offer, or take in the collector car auctions.

While many people headed home Sunday morning, others made the trip to Pebble Beach for the fabled concours, and then migrated back to the track for a second day of racing.

This weekend offers something for virtually any sophisticated automobile enthusiast. No, you won't find Monster Trucks or dirt track cars, but if you have an eye for automotive design, a passion for road racing or a love for Italian



Pantera International hosted an outstanding lunch at the track

De Tomaso cars ringed the banquet area as the crowd enjoyed the Hawaiian-style barbecue and entertainment

cars, Monterey is where you will find yourself filled almost to the point of overload in automobiliana.

Thanks to the efforts of Tony Harvey and Linda, and Todd Glycer, the weekend is even more enjoyable for POCA members. With next year's race featuring 100 Years of Ford Racing as the featured marque, it will become a not-to-be-missed event!